

GK1172  
Basics in Medicine

# Neuroscience and Neurology

Prof. Dr. Heinfried H. Radeke  
pharmazentrum frankfurt  
[www.radeke.de](http://www.radeke.de) → courses / lectures

Back to the Future: the molecular perspective of Freud

Female patient with a complete loss a conscious memory reacted perfectly fine to a subconsciously deposited memory of an electric shock. Due to an unconsciously stored memory (amygdala) she spontaneously retracted her hand from the doctor offering her a hand-shake on the next day. (~1835, decades before Freud)

Back to the Future: the molecular perspective of Freud

PROBLEM #1: **Shift from single cells to systems.**

PROBLEM #3: **Develop molecular sociology.**

Back to the Future: the molecular perspective of Freud

Mind and Matter

Freud drew his final model of the mind in 1933 (below left; color has been added). Dotted lines represented the threshold between unconscious and conscious processing. The superego repressed instinctual drives (the id), preventing them from disrupting rational thought. Most rational (ego) processes were automatic and unconscious, too, so only a small part of the ego (dub'd at top) was left to manage conscious experience, which was closely tied to perception. The superego mediated the ongoing struggle between the ego and id for dominance. Recent neurological mapping (right) generally correlates to Freud's conception. The core brain stem and limbic system—responsible for instincts and drives—roughly correspond to Freud's id. The ventral frontal region, which controls selective inhibition, the dorsal frontal region, which controls self-conscious thought, and the posterior cortex, which represents the outside world, amount to the ego and the superego.

Back to the Future: the molecular perspective of Freud

Freud sketched a neuronal mechanism for repression (above) in 1896, as part of his hope that biological explanations of the mind would one day replace psychological ones. In his scheme, an unpleasant memory would normally be activated by a stimulus ("Q", far left) heading from neuron "a" toward neuron "b" (bottom). But neuron "alpha" (to right of "a") could divert the signal and thus prevent the activation if other neurons (top right) asserted a "repressing" influence. Note that Freud drew gaps between neurons that he predicted would act as "contact barriers." Two years later English physiologist Charles Sherrington discovered such gaps and named them synapses.

IF THE HUMAN BRAIN WERE SO SIMPLE THAT WE COULD UNDERSTAND IT, WE WOULD BE SO SIMPLE THAT WE COULDN'T.

## NEURONS

- Basic functional unit of N.S.
- Specialized cell
  - All cells have same basic properties
- information processing
  - Transmits
  - Integrates
  - Stores
- Regulation of behavior

## By function (connections)

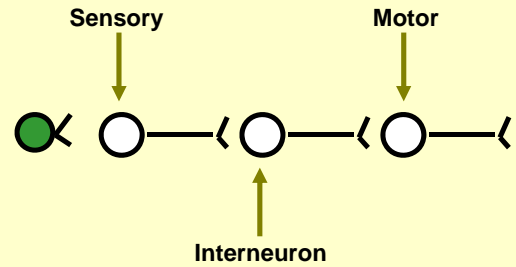

## By morphology (# of neurites)

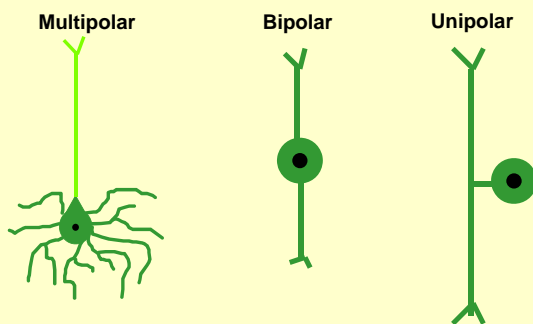

## Membrane Proteins: Ionophores

- Ions Channels
- Nongated
  - always open
- Gated
  - chemically-gated
  - electrically-gated
  - mechanically-gated

## Chemically-Gated Channels

- ligand-gated
  - receptor protein = channel
  - direct control ---> fast
- Metabotropic
  - second messenger system
  - indirect ---> slow

## Membrane Proteins

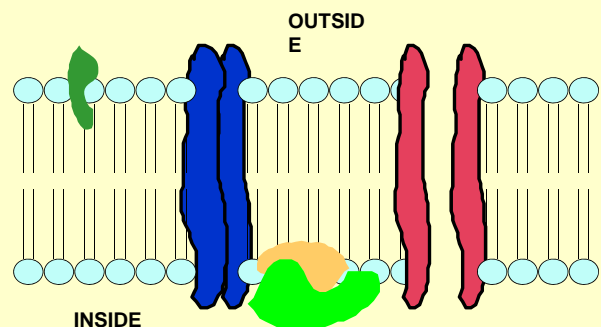

## Metabolic pumps

- Membrane proteins
- Pump ions
  - require energy
  - $\text{Na}^+ - \text{K}^+$
  - $\text{Ca}^{++}$  (calcium)
- Also various molecules
  - nutrients
  - neurotransmitters

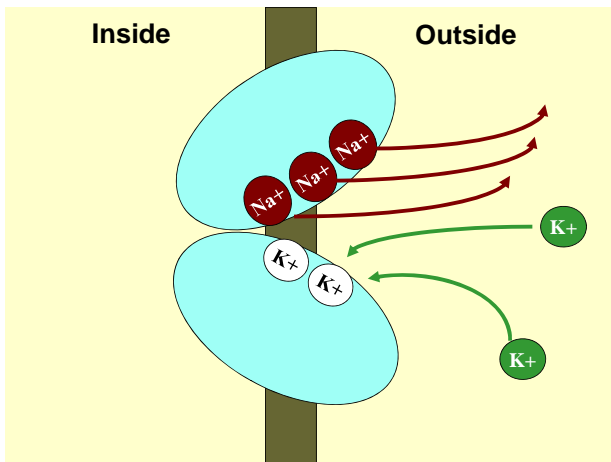
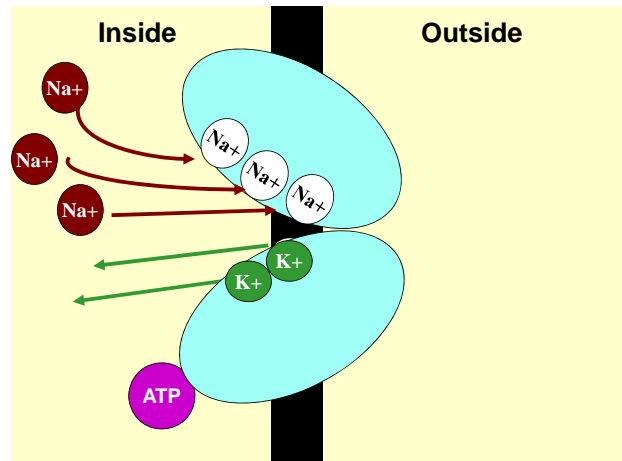

## AP Characteristics

- Voltage-gated channels
- All or none
- Slow
- Non-decremental
- Self Propagated
  - regenerated

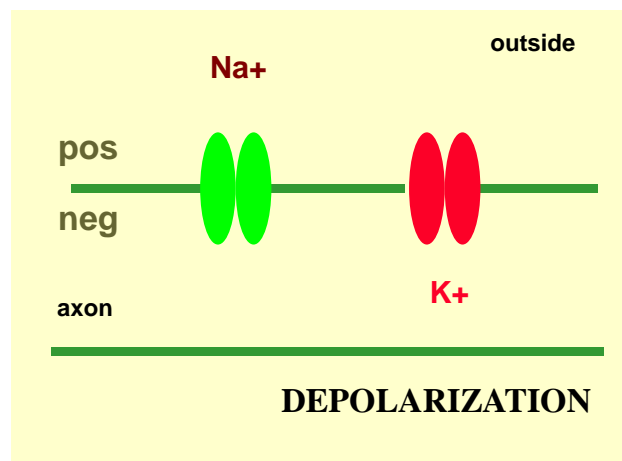
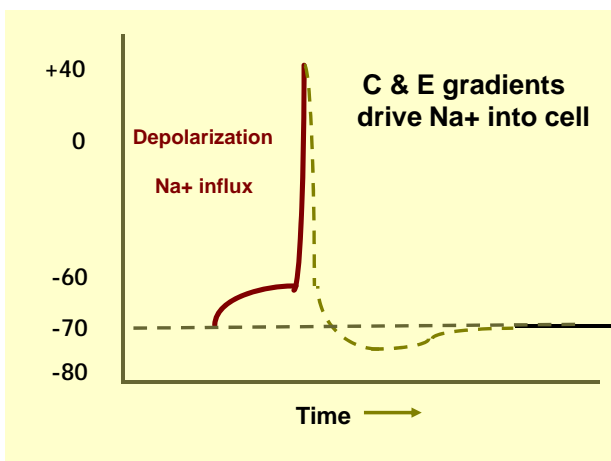

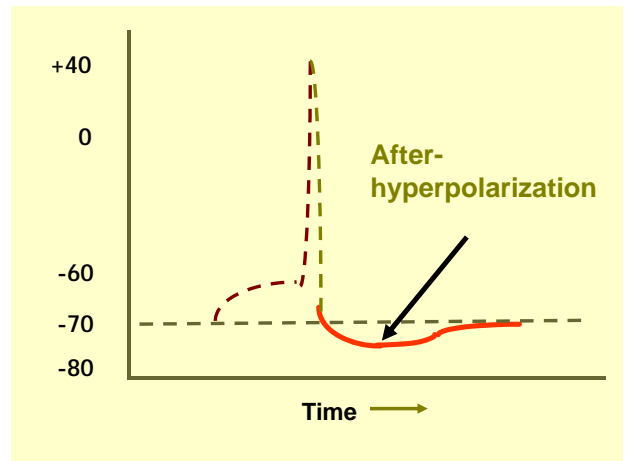
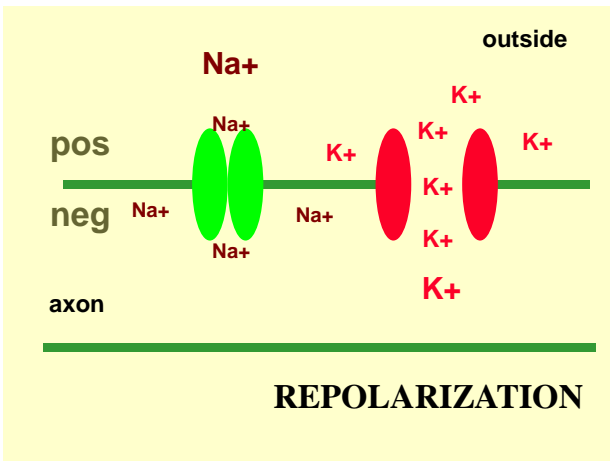
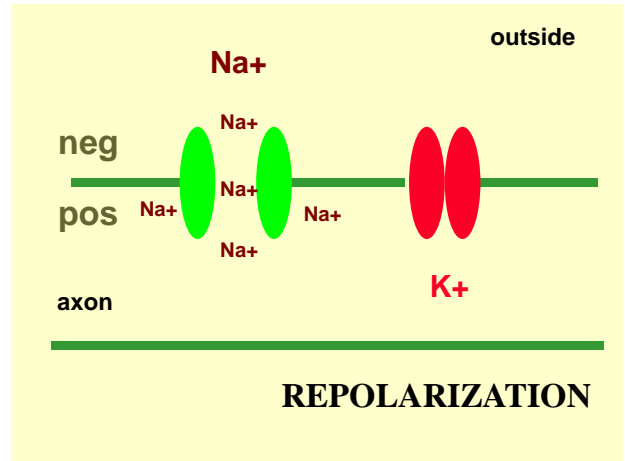
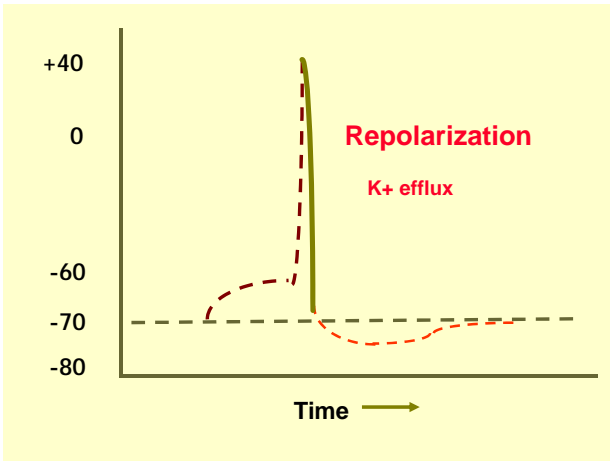
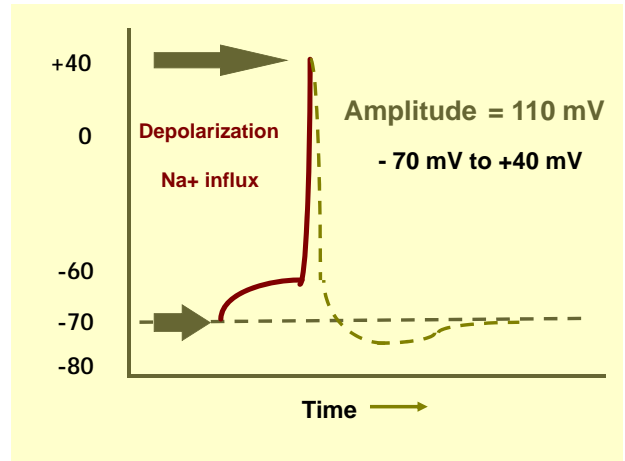
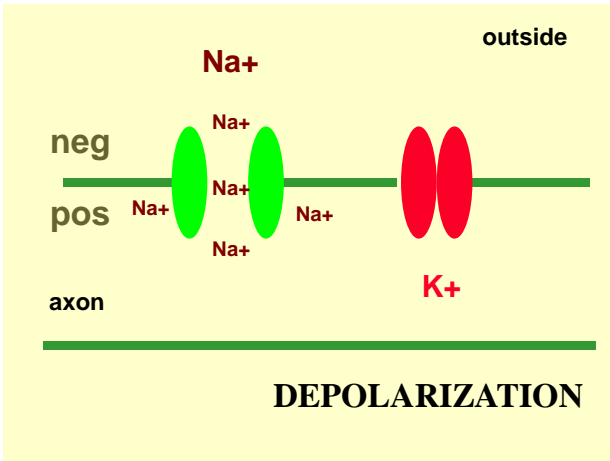

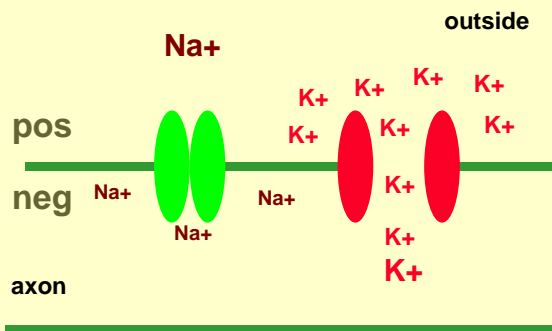

### AFTER-HYPERPOLARIZATION

### Refractory Period

- after AP  
won't fire again  
relative & absolute
- Relative  
during after hyperpolarization  
requires greater depolarization ~

### \*Frequency Code

- Pattern = Intensity of stimulus  
\*frequency of APs
  - Place = \*type of stimulus
    - Visual, auditory, pain, etc.
- Brain area that receives signal
- \* Doctrine of Specific Nerve Energies ~

### FREQUENCY CODE

Weak stimulus



Moderate stimulus



Strong stimulus



### Saltatory Conduction

- Myelinated neurons
  - oligodendroglia & Schwann cells
- Transmit long distances
  - APs relatively slow, regenerates
  - EPSPs - fast, decremental
- Saltatory: combines both types of current
  - speed without loss of signal

### Myelin

- Wrap around axon
- Saltatory Conduction
  - faster transmission
- CNS: oligodendroglia  
or oligodendrocytes
- PNS: Schwann cells

## Saltatory Conduction

- Nodes of Ranvier
  - action potentials
- Myelinated
  - like electricity through wire
  - decremental but triggers AP at next node
  - Safety factor - trigger AP across 5 nodes ~

## Saltatory Conduction

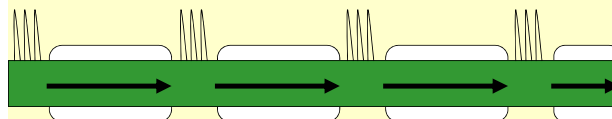

## Synaptic Events

- Action Potential reaches axon terminal
- Chemical substance released
  - Neurotransmitter (NT)
- Diffuses across synapse
- Binds to receptor protein

## Synaptic Transmission Model

- Precursor transport
- NT synthesis
- Storage
- Release
- Activation
- Termination

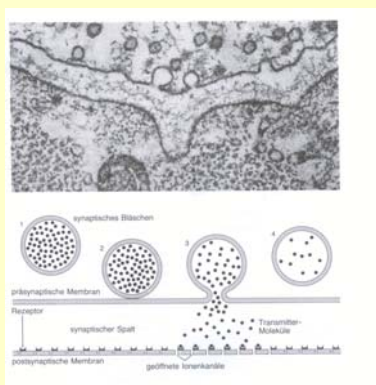

Presynaptic  
Axon Terminal

Postsynaptic  
Membrane

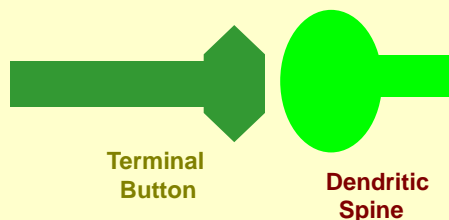

### 1. Precursor Transport

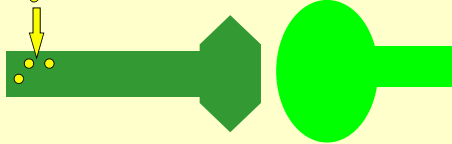

## Material Transport within Cells

- Proteins, etc
  - neurons: soma <----> axon
- Slow axonal transport:
  - anterograde: soma ---> axon
  - carried by cytosol flow
  - cytoskeletal elements & soluble proteins
  - up to 4 mm/day ~

## Material Transport within Cells

- Fast anterograde transport:
  - depends on oxidative metabolism
  - Organelles appear to walk along the microtubules
  - 400 mm/day ~

## Material Transport within Cells

- Fast retrograde transport:
  - axon ---> soma
    - also along microtubules
    - up to 300 mm/day
    - uses oxidative metabolism
  - Packaged in membrane-bound organelles
    - part of the lysosomal system
  - materials degraded or recycled

### 2. Synthesis

enzymes/cofactors

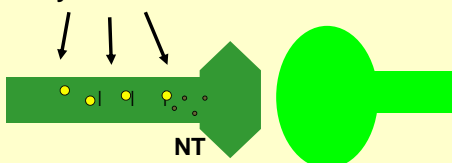

### 3. Storage

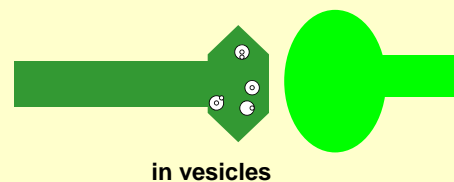

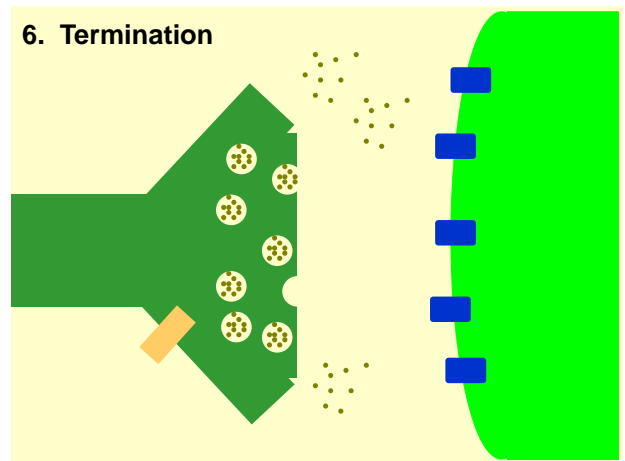
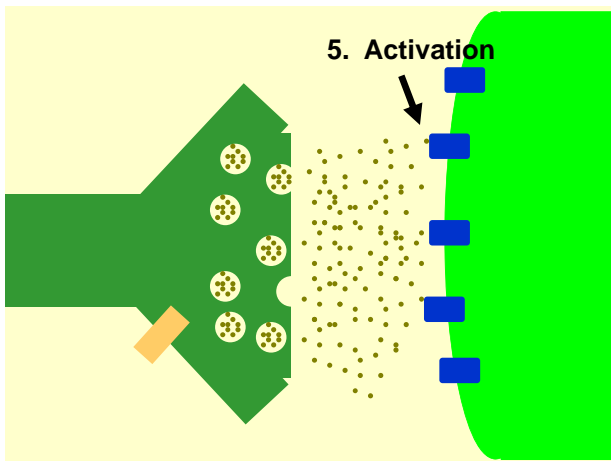
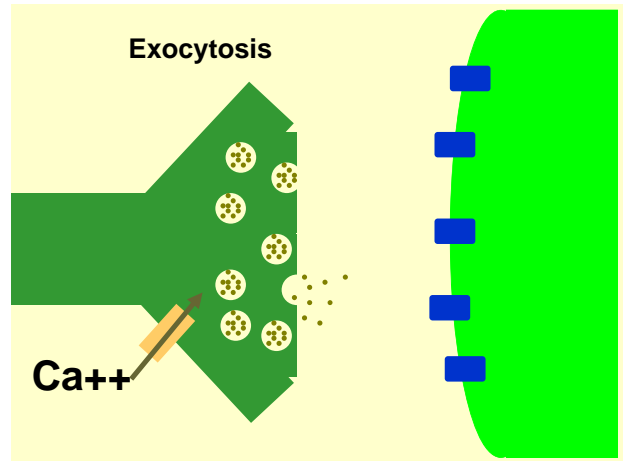
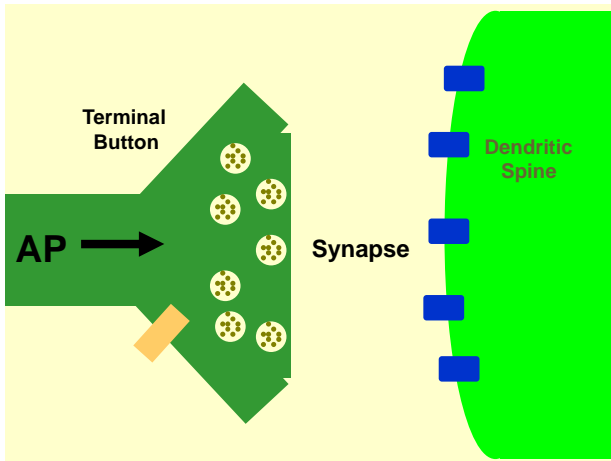
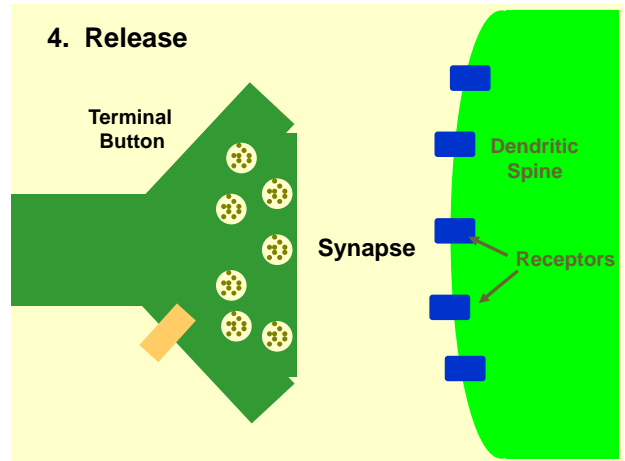
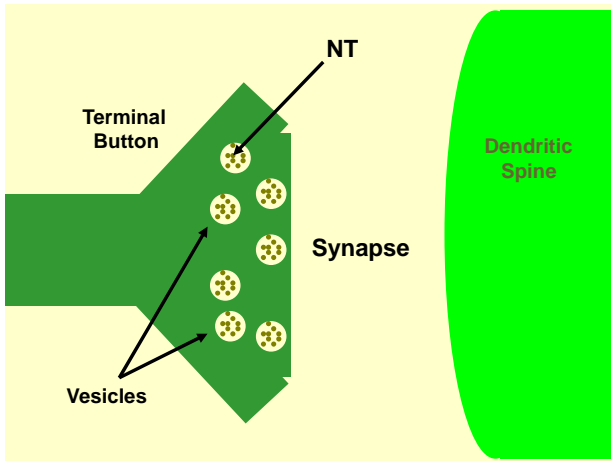

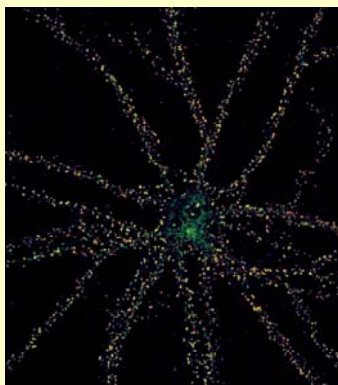
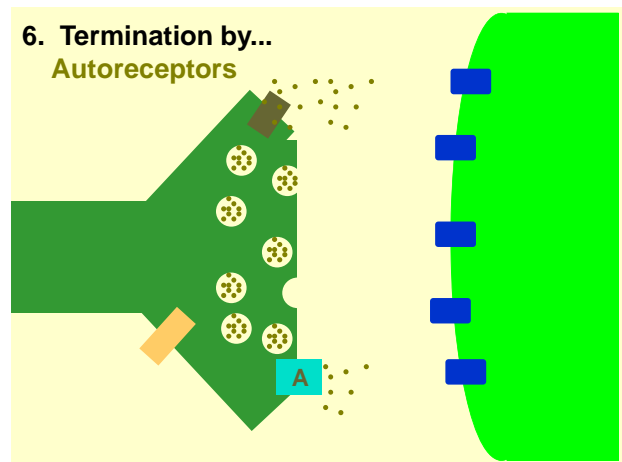
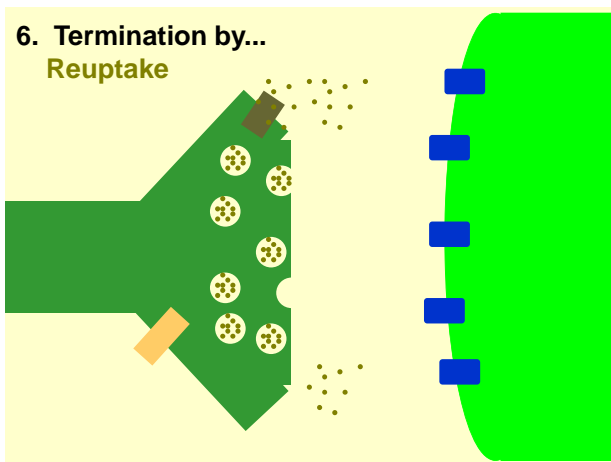
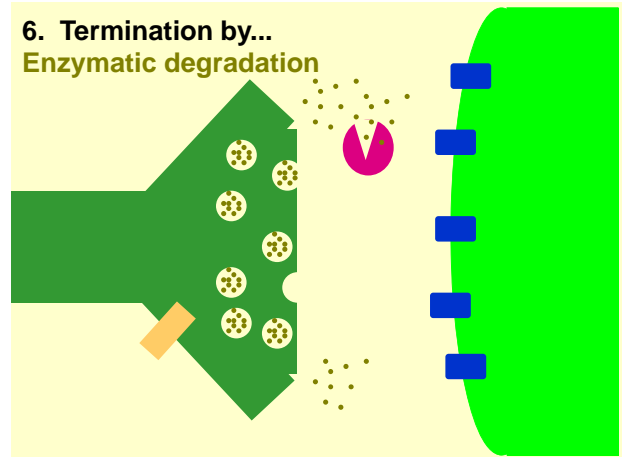
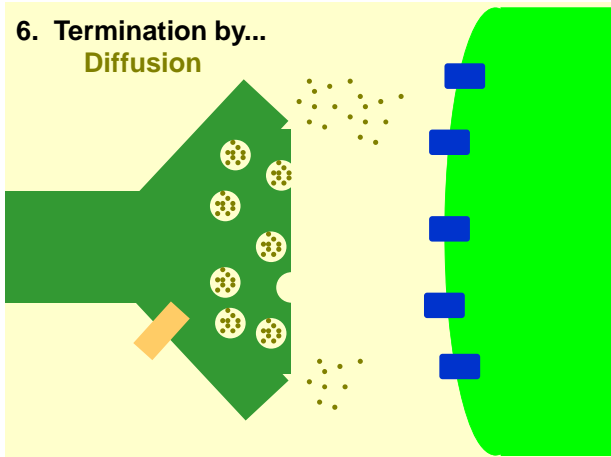

A single neuron may establish more than 10,000 connections to close or distant neurons.

In addition to electric signals more than 40 neurotransmitters.

As a „minute“ detail this figure shows the enhancement of NMDA (glutamatergic) receptor subunits in the striatum following long-term D1 (dopamin) stimulation. This process is involved in „motor learning /motion control“. (Fluorescence staining of a tyr-rec. subunit and an adaptor molecule)

NATURE REVIEWS NEUROSCIENCE VOL 7:419, 2006

**Memory consolidation of Pavlovian conditioning:  
a cellular and molecular perspective**



There is no such thing as „THE“ memory-device in the brain

	Autobiographical memory	Memory of facts	Procedural memory	priming
brain structures involved:	Limbic System	Limbic System Cerebral Cortex	Cerebellum Basal ganglia	Cerebral Cortex

Models of synaptic plasticity  
 BOOK: Spiking Neuron Models, W. Gerstner and W. Kistler  
 Cambridge University Press, 2002, Chapter 10-12

Chapter 10 = Hebb rules

Cellular mechanisms of learning and memory:  
 Hebb's rule



D. O. Hebb (1904-1985)

“When an axon of cell A is near enough to excite a cell B and repeatedly or persistently takes part in firing it, some growth process or **metabolic change** takes place in one or both cells such that A's efficiency, as one of the cells firing B, is increased.”

—Donald O. Hebb  
*The Organization of Behavior, 1949*

Associativity and the strengthening of synaptic connections

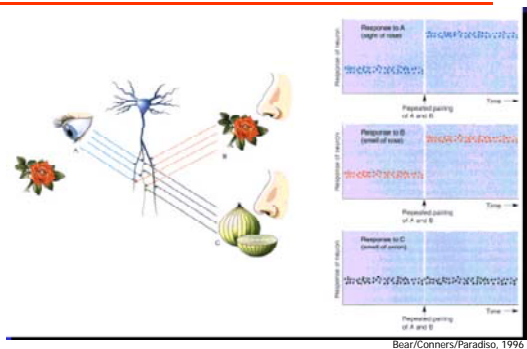

### Hebbian Learning

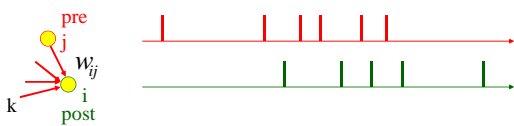

When an axon of cell  $j$  repeatedly or persistently takes part in firing cell  $i$ , then  $j$ 's efficiency as one of the cells firing  $i$  is increased

Hebb, 1949

- local rule
- simultaneously active (correlations)

### Hebbian Learning in experiments (schematic)

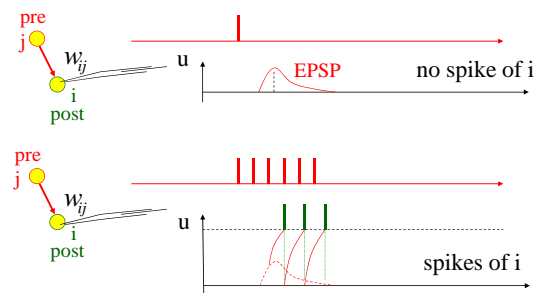

### Hebbian Learning in experiments (schematic)

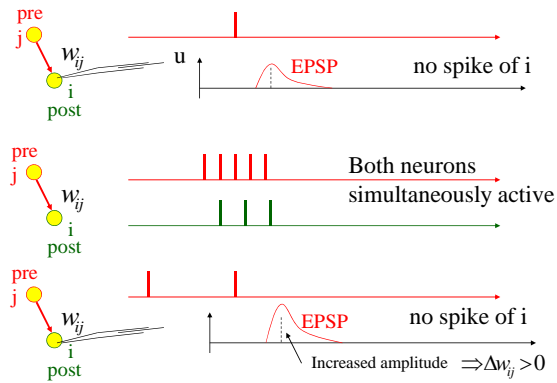

### Detailed models of Hebbian learning

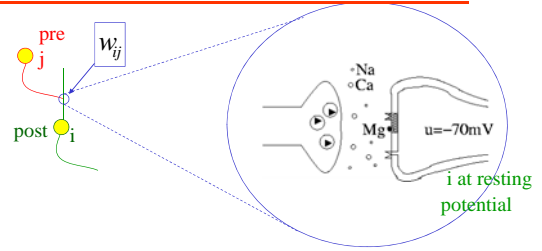

### Detailed models of Hebbian learning

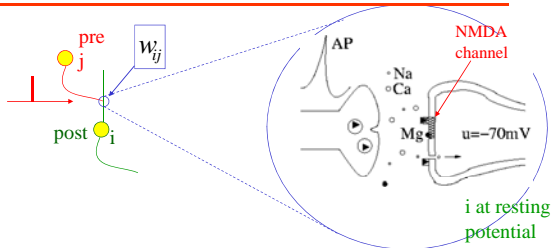

### Detailed models of Hebbian learning

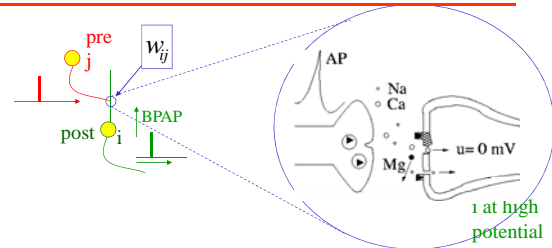

#### NMDA channel :

- glutamate binding after presynaptic spike
- unblocked after postsynaptic spike

→ elementary correlation detector

### Hebbian Learning

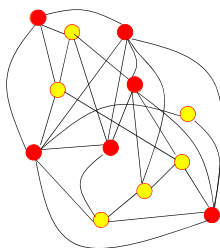

### Hebbian Learning

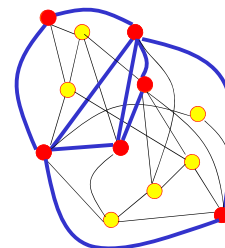

item memorized

## Hebbian Learning

Recall:  
Partial info

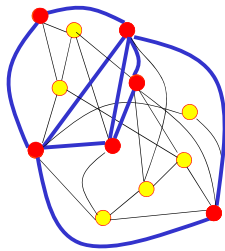

item recalled

## LTP Has Characteristics Expected of a Physiological Substrate for Memory

### Associativity

Requires concurrent events on both sides of the synapse (presynaptic glutamate release, postsynaptic depolarization)

### Specificity

Induced only at appropriately stimulated synapses, and not neighboring synapses

### Persistence

Is maintained for a long time following a brief period of synaptic activity

Modified PPT slides from Robert Blitzer - Mount Sinai School of Medicine - 2005

## Dendritic Events Associated with LTP at the CA3 - CA1 Synapse

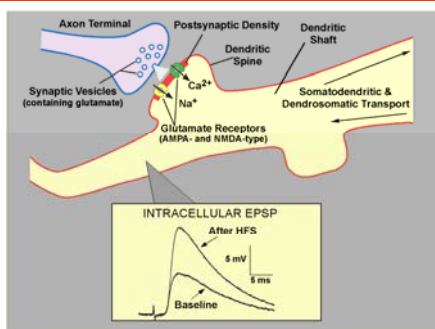

Modified PPT slides from Robert Blitzer - Mount Sinai School of Medicine - 2005

## NMDA receptor enhanced AMPA transmission via Ca Calmodulin Kinase II

Baseline Synaptic Transmission (AMPA-Mediated)

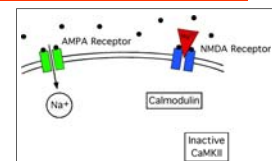

Contribution of NMDAR During LTP Induction

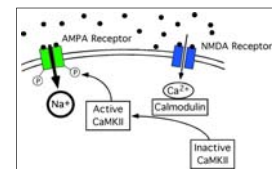

Modified PPT slides from Robert Blitzer - Mount Sinai School of Medicine - 2005

## CaMKII and NMDA Receptors Are in the Right Place

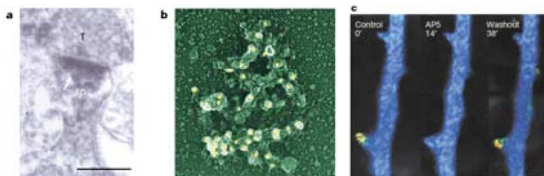

Lisman et al. *Nature Rev. Neurosci.* 3:175 (2002)

Modified PPT slides from Robert Blitzer - Mount Sinai School of Medicine - 2005

## Association in LTP: Sequence of Core Signaling Events at the Synapse

- 1) Presynaptic action potentials release glutamate into the synaptic cleft.
- 2) Glutamate binds to postsynaptic AMPA- and NMDA-type receptors.
- 3) The AMPA channels are opened, but the NMDA channels are blocked by extracellular  $Mg^{2+}$ .
- 4) With sufficient AMPA receptor-mediated membrane depolarization, the  $Mg^{2+}$  block of NMDA channels is relieved.  $Ca^{2+}$  enters the dendrite.

Modified PPT slides from Robert Blitzer - Mount Sinai School of Medicine - 2005

### Sequence of Core Signaling Events

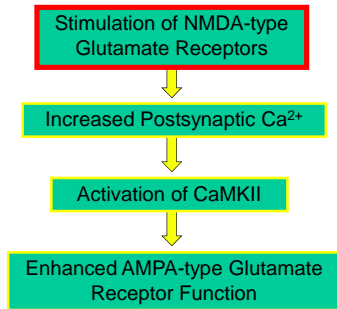

Modified PPT slides from Robert Blitzer - Mount Sinai School of Medicine - 2005

### One Way to Analyse Synaptic Plasticity (hippocampus as part of the subconscious memory devices)

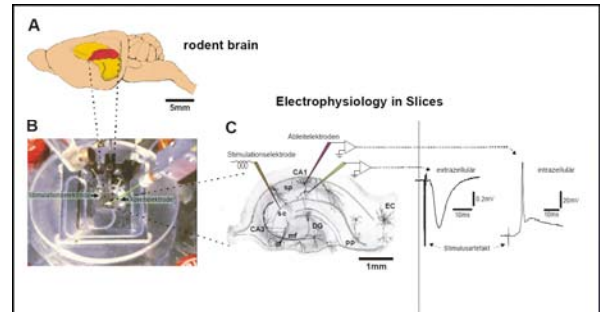

### Behavioural test for hippocampus dependent learning

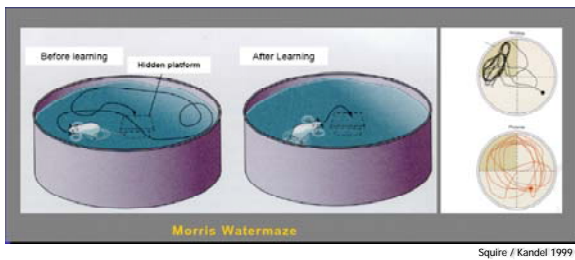

### Gen-knock-out limited to defined neurons

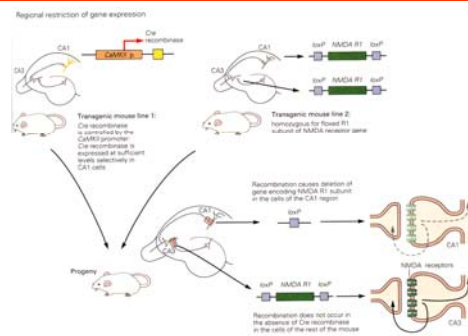

### Mice lacking the NMDA receptor in the CA1 region do not show LTP and exhibit spatial learning deficits

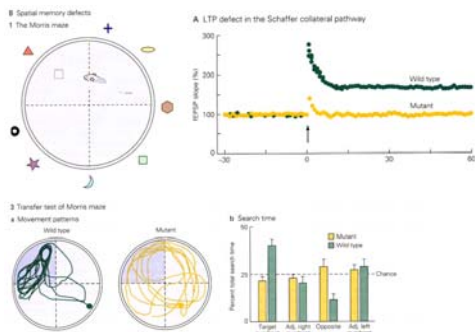

Modified PPT slides from Robert Blitzer - Mount Sinai School of Medicine - 2005

### Sequence of Core Signaling Events

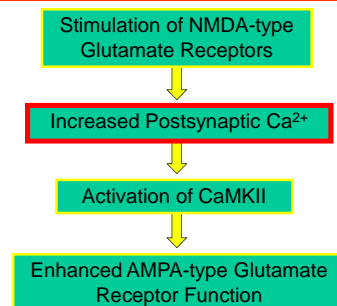

## LTP Induction Requires Postsynaptic Ca<sup>2+</sup>

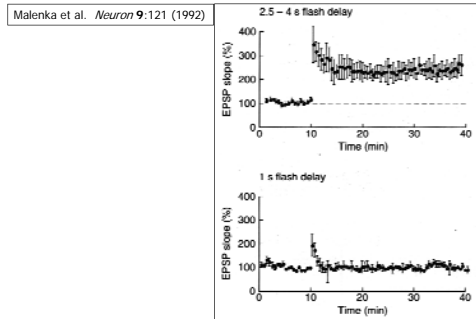

Modified PPT slides from Robert Blitzer - Mount Sinai School of Medicine - 2005

## Sequence of Core Signaling Events

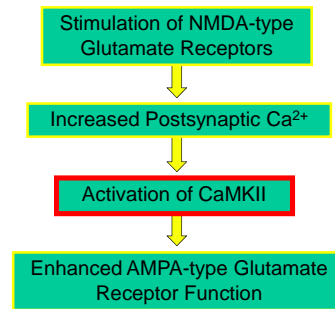

Modified PPT slides from Robert Blitzer - Mount Sinai School of Medicine - 2005

## During LTP, CaMKII is Activated in Dendrites

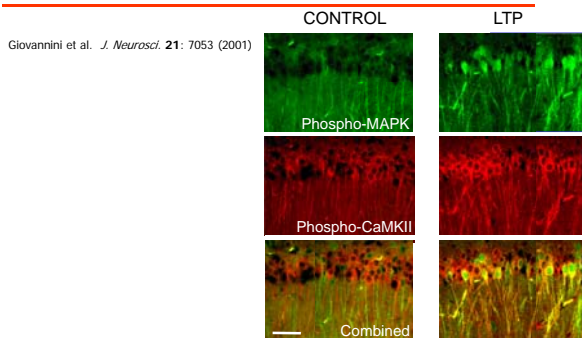

Modified PPT slides from Robert Blitzer - Mount Sinai School of Medicine - 2005

## Sequence of Core Signaling Events

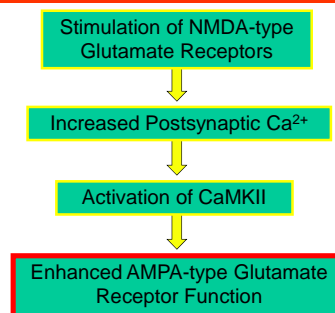

Modified PPT slides from Robert Blitzer - Mount Sinai School of Medicine - 2005

## LTP Induction Phosphorylates AMPA Receptors in a CaMKII-dependent manner

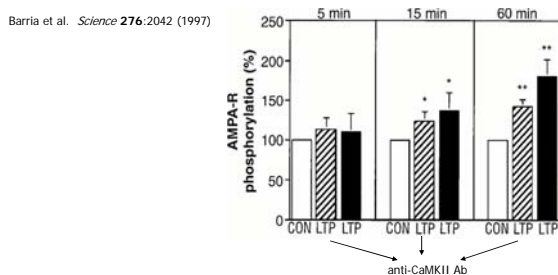

Modified PPT slides from Robert Blitzer - Mount Sinai School of Medicine - 2005

... then a miracle occurs

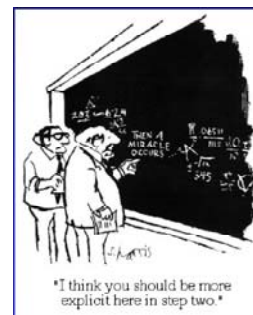

## Cellular mechanisms of learning and memory: Hebbs' rule



D. O. Hebb (1904-1985)

"When an axon of cell A is near enough to excite a cell B and repeatedly or persistently takes part in firing it, some growth process or metabolic change takes place in one or both cells such that A's efficiency, as one of the cells firing B, is increased."

—Donald O. Hebb  
*The Organization of Behavior, 1949*

## Functional Changes can lead to Structural Changes

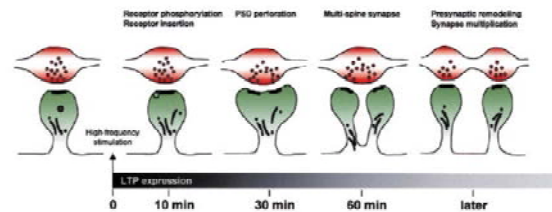

Synaptic plasticity and dynamic modulation of the postsynaptic membrane. Luscher et al. nature neuroscience • volume 3 no 6 • June 2000

## Input-specific Synaptic Plasticity provides tremendous computational capacity

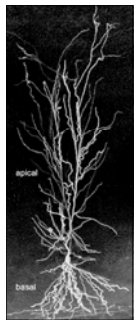

Fiala & Harris in *Dendrites* (Stuart et al., eds.)  
Oxford University Press (1999)



Modified from Brunson et al.  
*J. Neurosci.* 25: 9328-38 (2005)

Modified PPT slides from Robert Blitzer - Mount Sinai School of Medicine - 2005

## „Live“ Recordings of Structural Plasticity

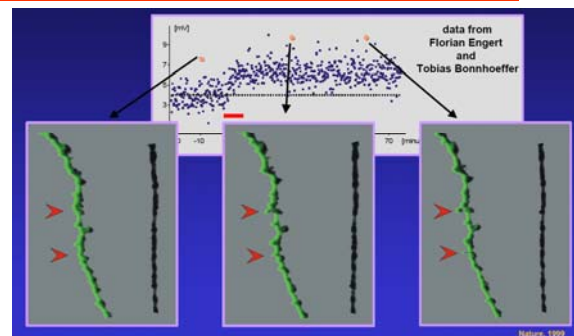

## Neurotrophins and their Receptors

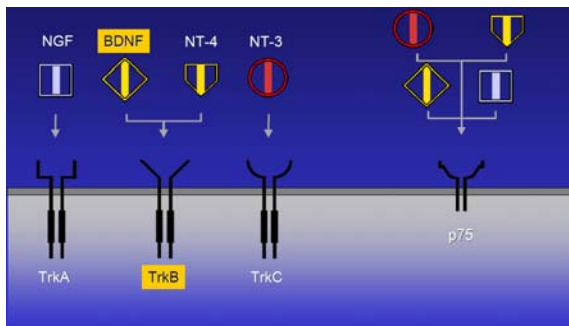

## Hints about Neurotrophins and Synaptic Plasticity

- neurotrophins can be released in an activity dependent manner
- neurotrophins are synthesized in an activity dependent manner
- neurotrophins can increase neurotransmitter release
- neurotrophins can change dendritic structure

## Neurotrophins and their Receptors

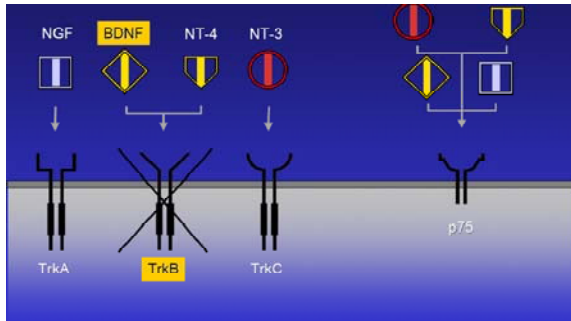

## Conditional TrkB-KO mice: the CRE / loxP-System

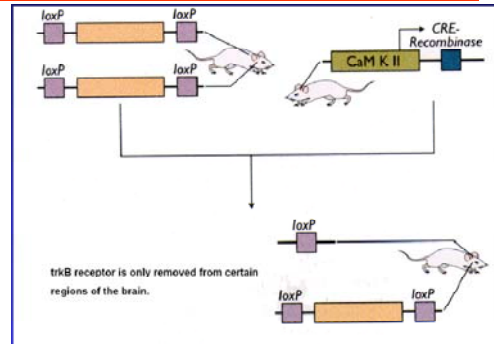

## TrkB-Cre-KO Mice : Defect in LTP

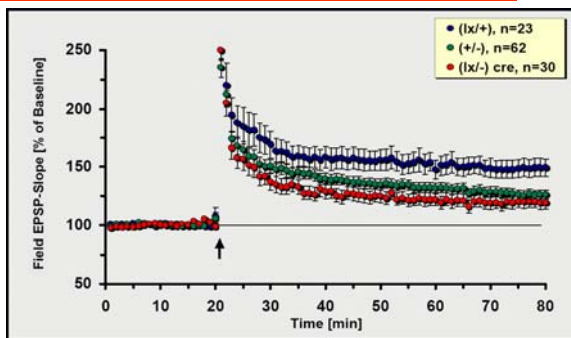

## TrkB-Cre-KO Mice in the Morris Watermaze

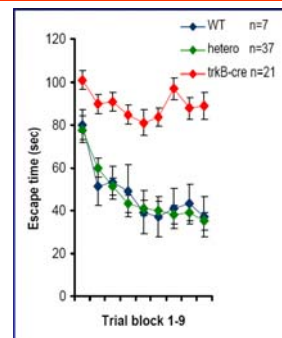

## Molecular basis of long-term potentiation (LTP) Summary

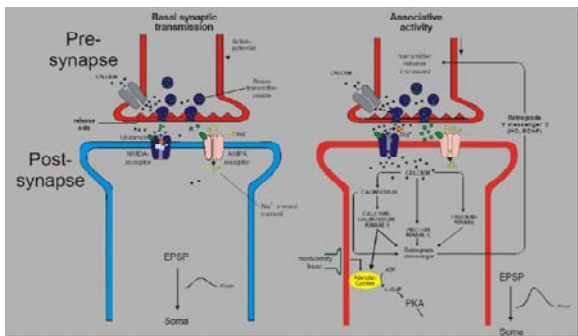

## Building a Smarter Rodent

### Method #1 Overexpress NMDA Receptors

Modified PPT slides from Robert Blitzer - Mount Sinai School of Medicine - 2005

## Overexpression of NMDA Receptors Improves LTP ...

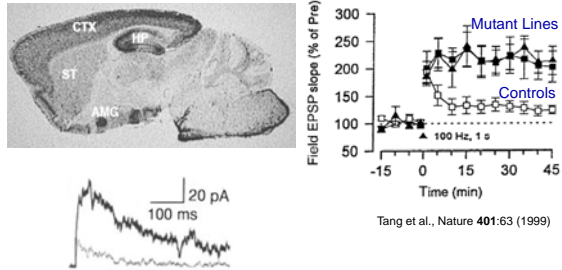

Modified PPT slides from Robert Blitzer - Mount Sinai School of Medicine - 2005

## ... and Improves Recognition/Spatial Memory

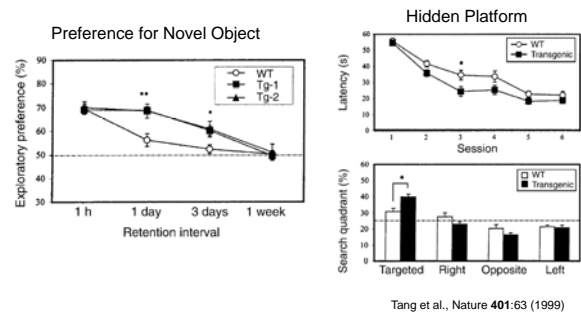

Modified PPT slides from Robert Blitzer - Mount Sinai School of Medicine - 2005

## Building a Smarter Rodent

### Method #2 Inhibit Calcineurin

Modified PPT slides from Robert Blitzer - Mount Sinai School of Medicine - 2005

## Blocking Calcineurin Should Improve LTP

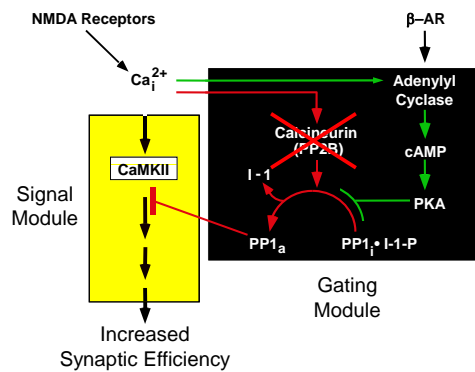

Modified PPT slides from Robert Blitzer - Mount Sinai School of Medicine - 2005

## Inducible Expression of a Calcineurin Blocker Improves LTP

Malleret et al., Cell 104:675 (2001)

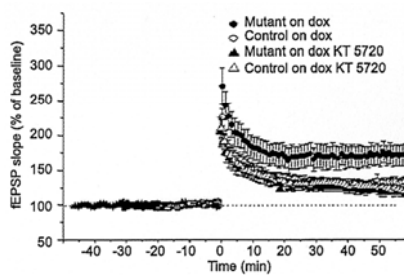

Modified PPT slides from Robert Blitzer - Mount Sinai School of Medicine - 2005

## Calcineurin Blockade Also Improves Recognition / Spatial Learning

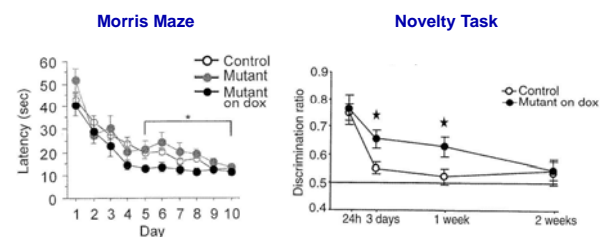

Malleret et al., Cell 104:675 (2001)

Modified PPT slides from Robert Blitzer - Mount Sinai School of Medicine - 2005

LTP and synaptic plasticity to understand and improve stroke therapy

Plasticity during stroke recovery: from synapse to behaviour

Timothy H. Murphy<sup>\*1\*</sup> and Dale Corbett<sup>2†</sup>

Nature Reviews Neuroscience 10:861-872 December 2009

LTP and synaptic plasticity to understand and improve stroke therapy

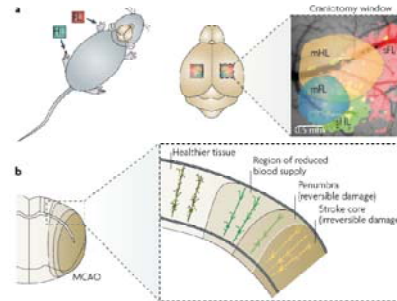

LTP and synaptic plasticity to understand and improve stroke therapy

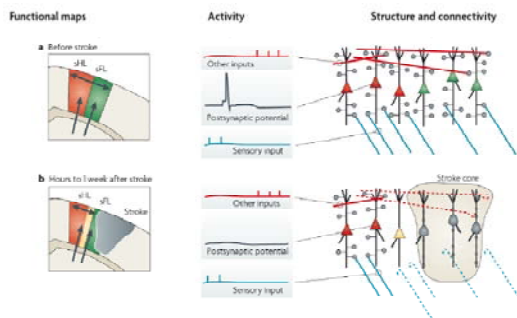

LTP and synaptic plasticity to understand and improve stroke therapy

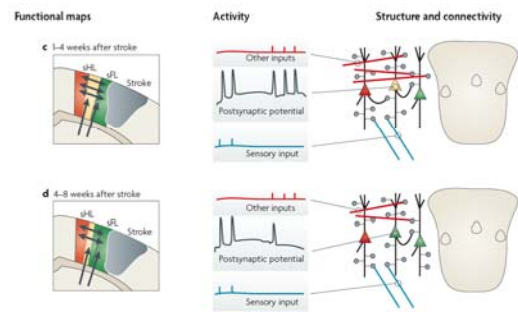

What we can do before and after stroke...

Running enhances neurogenesis, learning, and long-term potentiation in mice

Henriette van Praag<sup>1</sup>, Brian R. Christie<sup>1\*</sup>, Terrence J. Sejnowski<sup>1\*</sup>, and Fred H. Gage<sup>1\*</sup>

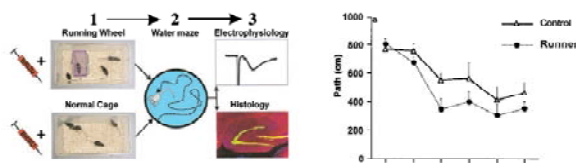

Fig. 1. Flowchart of the experiment. Controls were housed in standard 3D by

\* PNAS 96:13427-13431, 1999